

Electric supply connection:  
AC 400V; 50HZ; 3PH+PE 6.5kW; 15A

Flocculant station inlet:  
F1/2"  
Use pure water only.

Flocculant station discharge:  
F3/4"

Compressed air supply:  
Ø10mm-3/8"

Clarified water unloading pipe:  
Ø102mm-4in

Wastewater loading pipe:  
Ø60mm-2.4in

Drainage channel pipe:  
Ø50mm-2in

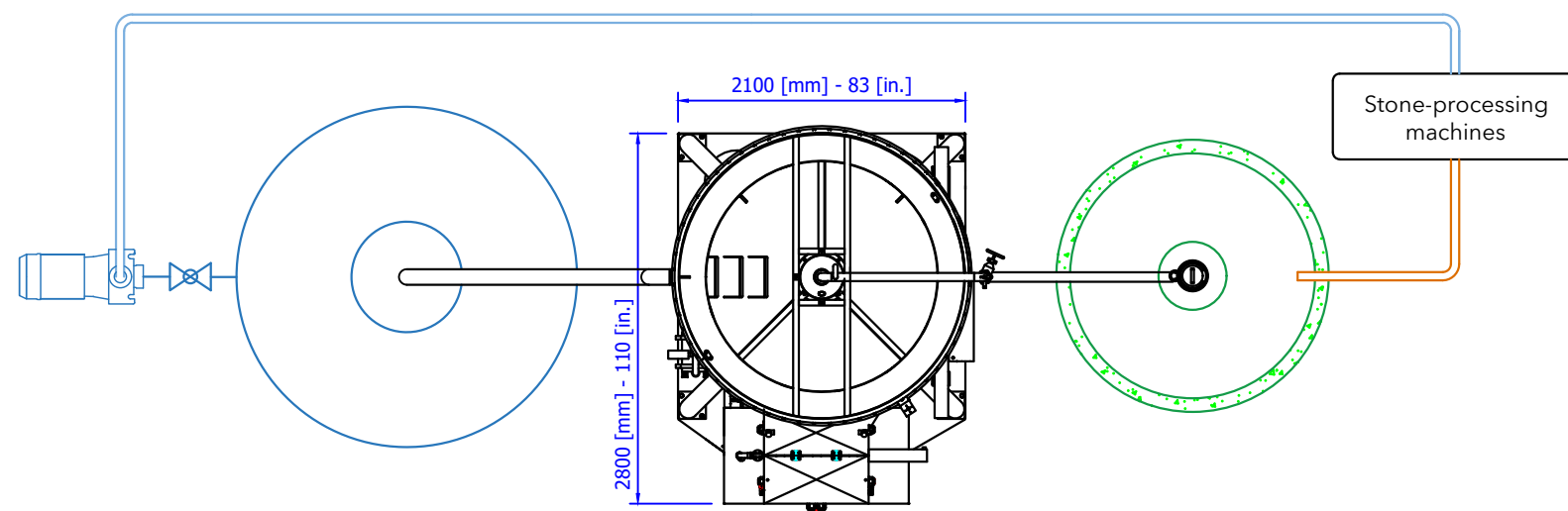
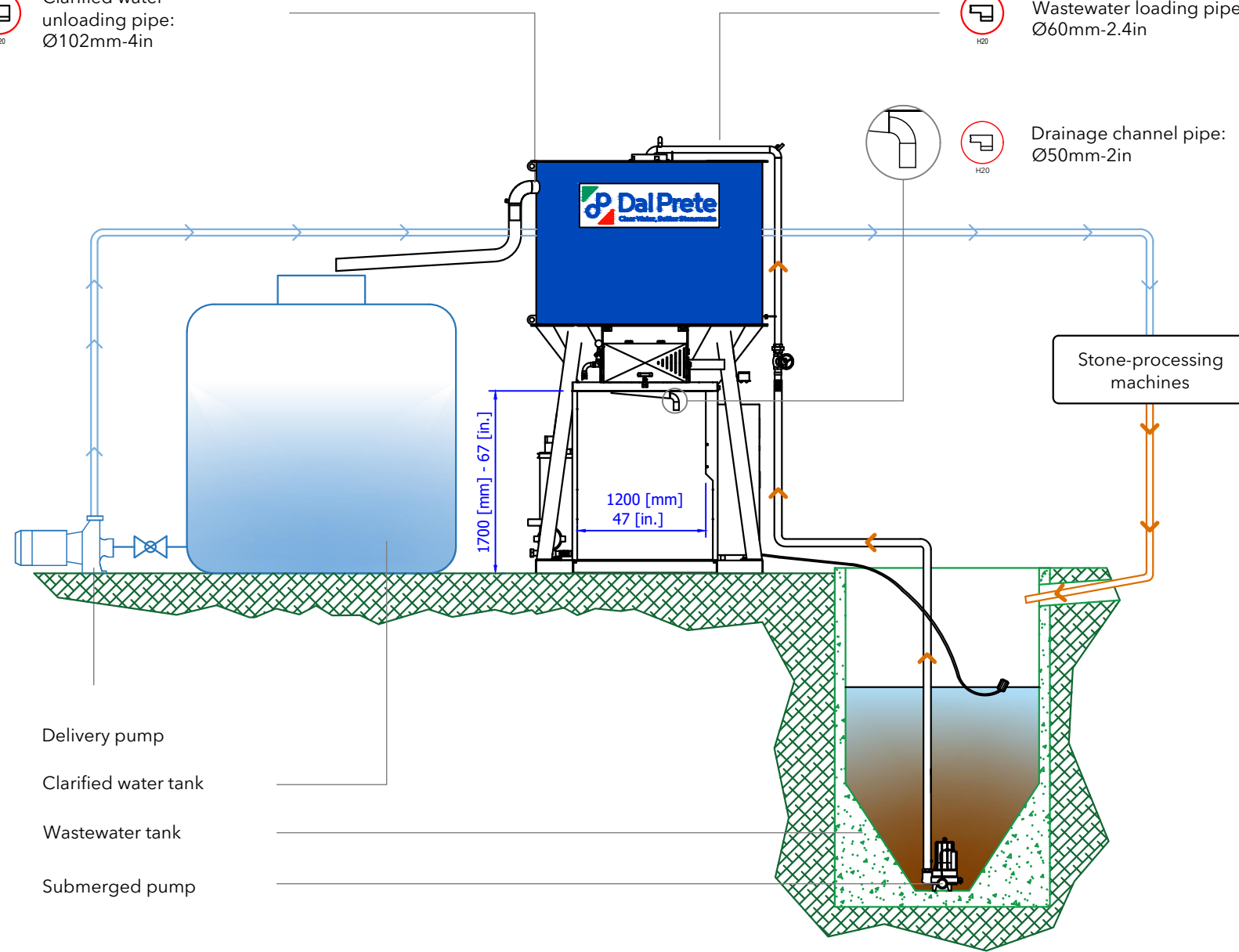

MACCHINA TIPO:  
MACHINE TYPE:

Water clarification and sludge dehydration plant

**MINI COMPACT L 2.1 (300 lt)**

Serial Number: \_\_\_\_\_

CLIENTE:  
CUSTOMER:

LAY-OUT DI MASSIMA  
(plant lay-out)

CODICE DISEGNO  
(drawing code)

DATA  
(date)

APPROVATO  
(approved)

