



 Electric supply connection:
AC 400V; 50HZ; 12.5kW; 24A
3PH + PE; FG16OR12 0,6/4kV 4G10

 Compressed air supply:
Ø10mm-3/8"

 Flocculant station discharge:
Ø19mm-Ø3/4"

 Flocculant station inlet:
Ø19mm-Ø3/4"
Use pure water only.

 Water connection for clothes washing system:
Ø60mm-2.4in
To be connected to the stone-processing machines' water supply

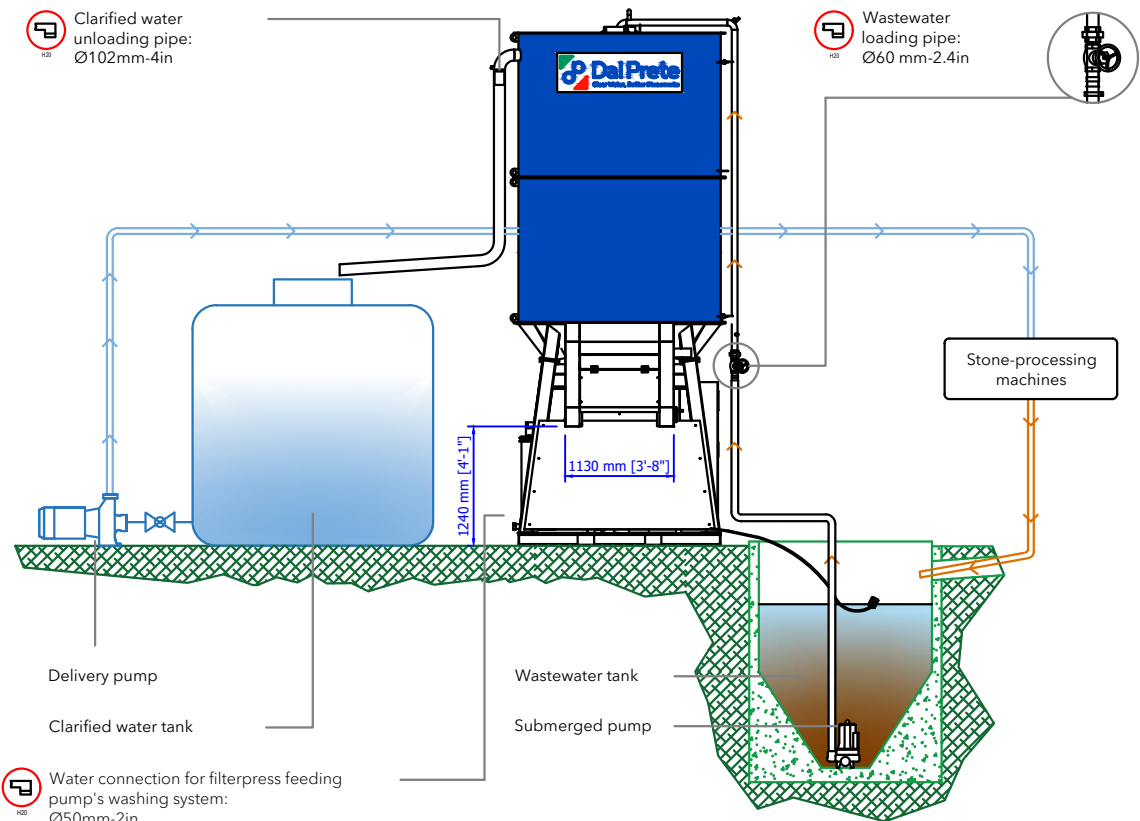

 Water connection for filterpress feeding pump's washing system:
Ø50mm-2in
To be connected directly to the clarified water tank

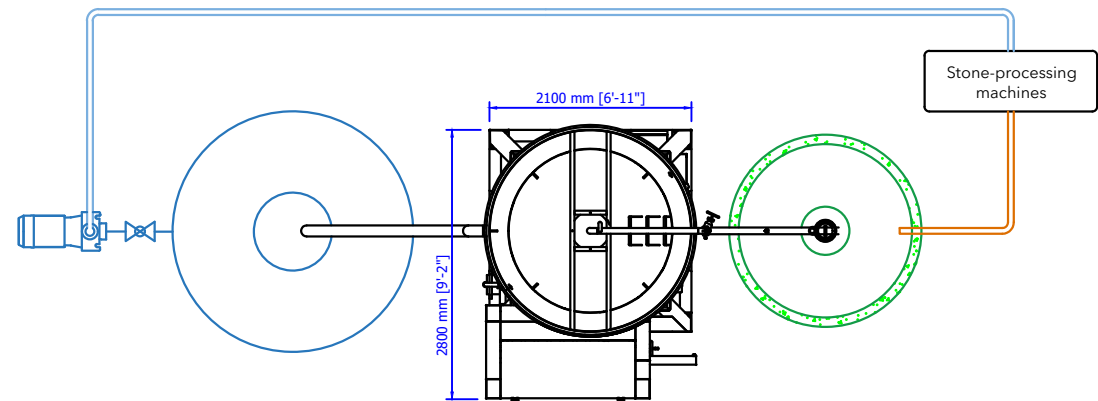

MACCHINA TIPO:
MACHINE TYPE:

Water clarification and sludge dehydration plant

MINI COMPACT M 3.1 600L

Serial Number: _____

CLIENTE:
CUSTOMER:

LAY-OUT DI MASSIMA
(plant lay-out)

CODICE DISEGNO
(drawing code)

DATA
(date)

APPROVATO
(approved)

