

Clarified water unloading pipe:
Ø89mm-3,5in

H2O

Wastewater loading pipe:
Ø50mm-2in

H2O

Drainage channel pipe:
Ø50mm-2in

H2O

Sludge tank

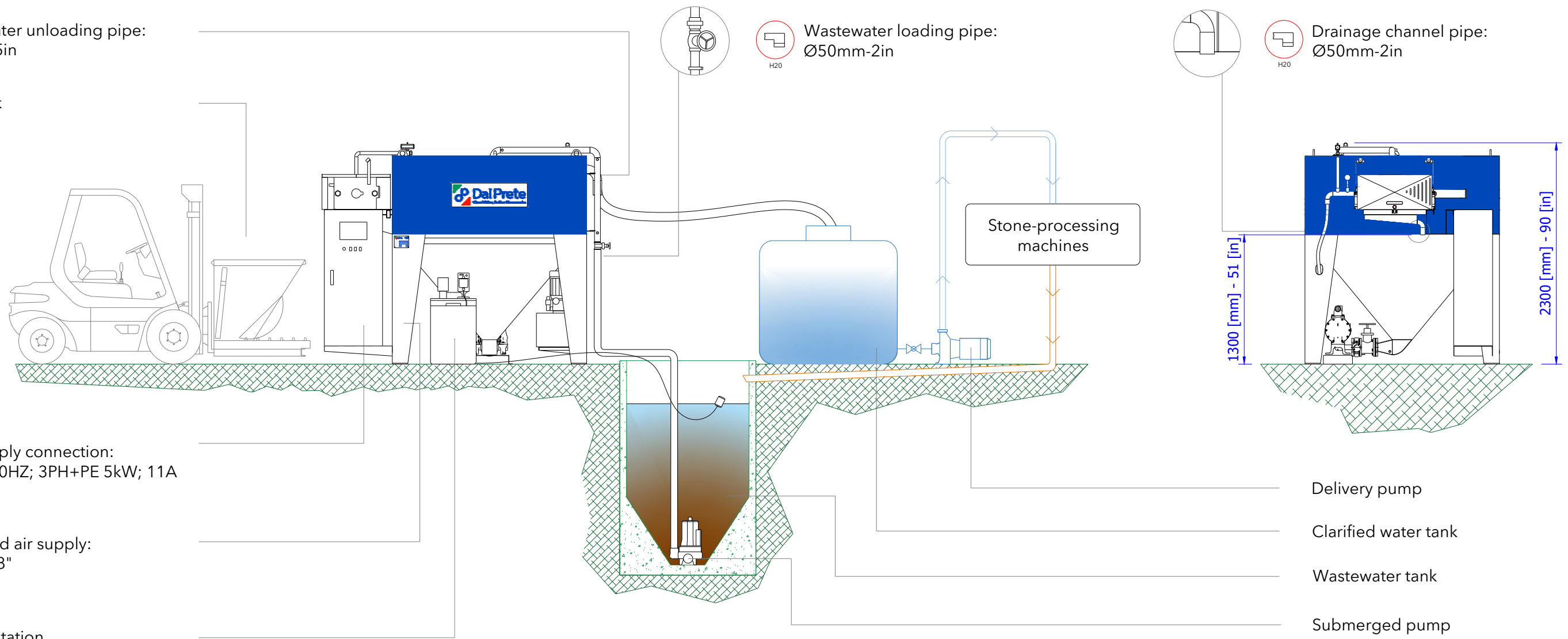

Electric supply connection:
AC 400V; 50HZ; 3PH+PE 5kW; 11A

ELECTRIC SUPPLY

Compressed air supply:
Ø10mm-3/8"

COMPRESSED AIR

Flocculant station

Delivery pump

Clarified water tank

Wastewater tank

Submerged pump

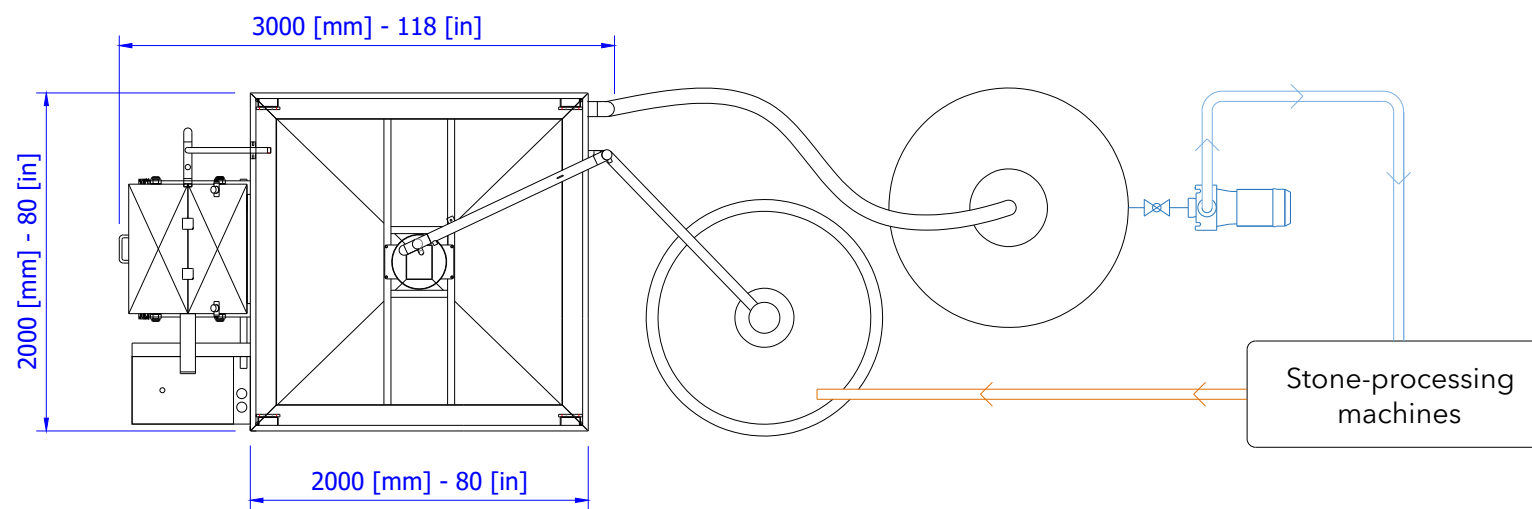

MACCHINA TIPO:
MACHINE TYPE:

Water clarification and sludge dehydration plant

EASY COMPACT

Serial Number: _____

CLIENTE:
CUSTOMER:

LAY-OUT DI MASSIMA
(plant lay-out)

CODICE DISEGNO
(drawing code)

DATA
(date)

APPROVATO
(approved)

